

CAD FILE:

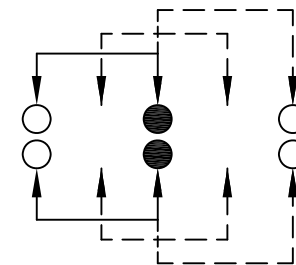

SCHEMATIC (SHORTING)

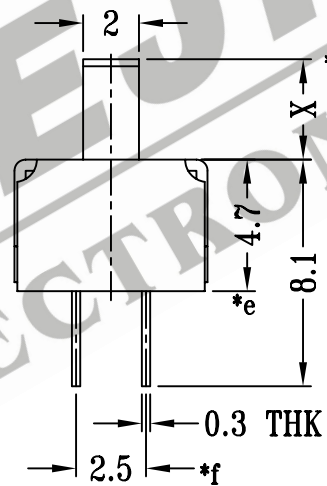
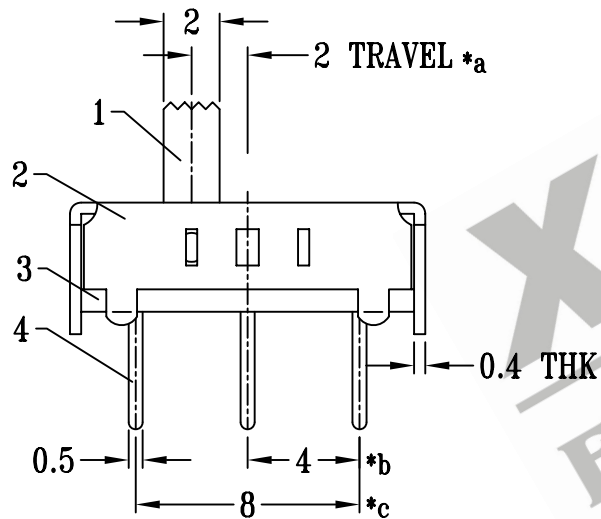
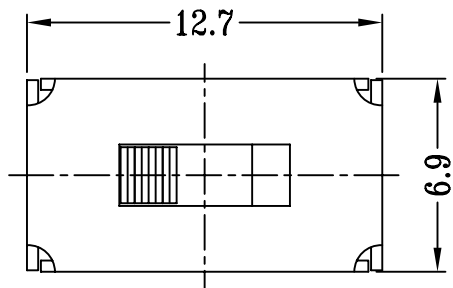
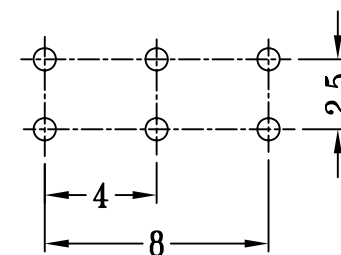

P.C.B LAYOUT

注:带"*"表示关键尺寸(6个)

NO.	PARTS	MATERIALS	Q'TY	FINISH	TOLERANCE UNLESS SPECIFIED	SHENZHEN XIEJIA ELECTRONICS CO.,LTD.				
8										
7										
6	SPRING PLATE	STAINLESS STEEL	2	NATURAL	WITHIN: 1.5±0.1mm	ISSUE	DATE	DESCRIPTIONS OF REVISION		APPD.
5	CONTACT CLIP	PBS	2	Ag CLAD	OVER : 1.5±0.2mm					
4	TERMINAL	BRASS STRIP	6	Ag PLATED OVER Ni PLATED	TITLE : VERTICAL SLIDE SWITCH		UNIT : mm	DRWG NO.: XJ-DR-SS23D11-00		
3	BASE	PHENOLIC RESIN	1	NATURAL	MODEL: SS-23D11		SCALE: 7 : 2	DWN.	ZHOUYU	2004-11-7
2	FRAME	STEEL STRIP	1	Ni PLATED				CHK'D	FANGYING	2004-11-7
1	KNOB	POM	1	BLACK	ALL MATERIALS MUST BE COMPLIANT TO ROHS			APPD.	KANGXINAN	2004-11-7